

DESCRIPTION

Silicon N-channel enhancement mode vertical D-MOS transistor designed for large signal amplifier applications in the VHF/UHF frequency range.

FEATURES

- Output Power: 45 W
- Power Gain: 10 dB Min@500M, 28V
- Efficiency: 50% Min

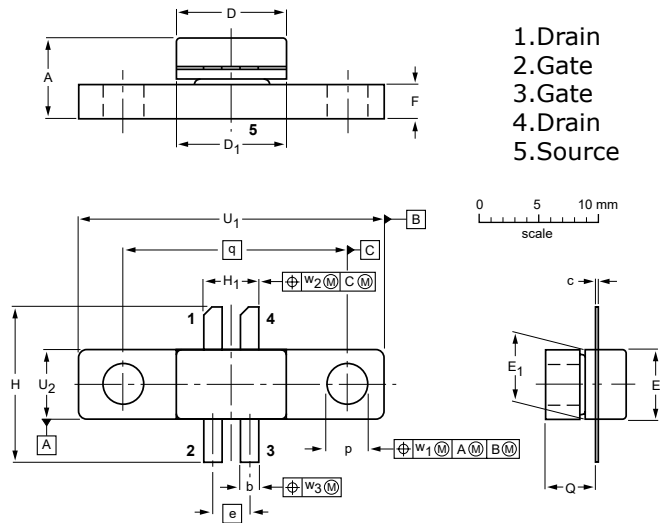

DIMENSIONS

UNIT	A	b	c	D	D ₁	E	E ₁	e	F	H	H ₁	p	Q	q	U ₁	U ₂	w ₁	w ₂	w ₃
mm	6.84 6.01	1.65 1.40	0.15 0.10	9.25 9.04	9.27 9.02	5.94 5.74	5.97 5.72	3.05	3.05 2.54	12.96 11.94	4.96 4.19	3.48 3.23	4.34 4.04	18.42	24.90 24.64	5.97 5.72	0.25	0.51	0.25
inches	0.269 0.237	0.065 0.055	0.006 0.004	0.364 0.356	0.365 0.355	0.234 0.226	0.235 0.225	0.120	0.120 0.100	0.510 0.470	0.195 0.165	0.137 0.127	0.171 0.159	0.725	0.980 0.970	0.235 0.225	0.010	0.020	0.010

MAXIMUM RATINGS

CHARACTERISTICS	SYMBOL	RATINGS	UNITS
Drain-Source Voltage	V _{DSS}	65	V
Gate-Source Voltage	V _{GS}	±20	V
Drain Current — Continuous	I _D	6.5	A
Total Device Dissipation	P _D	110	W
Junction Temperature	T _J	200	°C
Storage Temperature Range	T _{STG}	-65 to +150	°C

ELECTRICAL CHARACTERISTICS

CHARACTERISTICS	SYMBOL	TEST CONDITIONS	MIN.	TYP.	MAX	UNITS
Drain-Source Breakdown Voltage	V _{(BR)DSS}	I _D =20mA, V _{GS} =0	65	-	-	V
Zero Gate Voltage Drain Current	I _{DSS}	V _{GS} =0V, V _{DS} =28V	-	-	1	mAdc
Gate-Source Leakage Current	I _{GSS}	V _{GS} =±20V, V _{DS} =0V	-	-	1	uAdc
Gate Threshold Voltage	V _{GS(th)}	V _{DS} = 10 V, I _D = 0.1A	2.0	-	5.0	V
Drain-Source On-State Resistance	R _{dson}	V _{GS} = 20 V, I _D = 2.5A	-	1.1	-	Ohm
Forward Transconductance	g _{fs}	V _{DS} = 10 V, I _D = 0.75A	600	900	-	mS
Input Capacitance	C _{iss}	V _{DS} = 28 V, V _{GS} = 0 V, f = 1.0 MHz	-	45	-	pF
Output Capacitance	C _{oss}		-	38	-	pF
Reverse Transfer Capacitance	C _{rss}		-	3.8	-	pF
Common Source Power Gain	G _P	V _{DD} =28V, P _{OUT} =45W,	10.0	-	-	dB
Drain Efficiency	η _D	f=500MHz	50	-	-	%

Note : Above parameters , ratings , limits and conditions are subject to change.