

DESCRIPTION

Silicon N-channel enhancement mode vertical D-MOS transistor. Designed for broadband HF and VHF applications. The high power, high gain and broadband performance of this device makes possible solid state transmitters for FM broadcast or TV channel frequency bands.

FEATURES

- Output Power: 150 W
- Power Gain: 14 dB Typ@108M, 28V
17 dB Min@30M, 28V
- Efficiency: 35% Min

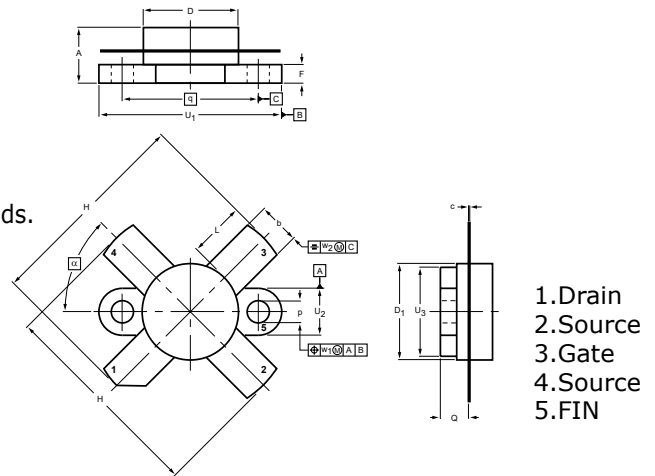

DIMENSIONS

NOTE: ALL ELECTRODES ARE ISOLATED FROM FLANGE.

UNIT	A	b	c	D	D ₁	F	H	L	p	Q	q	U ₁	U ₂	U ₃	w ₁	w ₂	α
mm	7.27	5.82	0.16	12.86	12.83	2.67	28.45	7.93	3.30	4.45	18.42	24.90	6.48	12.32	0.51	1.02	45°
	6.17	5.56	0.10	12.59	12.57	2.41	25.52	6.32	3.05	3.91		24.63	6.22	12.06			
inches	0.286	0.229	0.006	0.506	0.505	0.105	1.120	0.312	0.130	0.175	0.725	0.98	0.255	0.485	0.02	0.04	
	0.243	0.219	0.004	0.496	0.495	0.095	1.005	0.249	0.120	0.154		0.97	0.245	0.475			

MAXIMUM RATINGS

CHARACTERISTICS	SYMBOL	RATINGS	UNITS
Drain-Source Voltage	V _{DS}	65	V
Gate-Source Voltage	±V _{GS}	20	V
Drain Current — Continuous	I _D	25	A
Total Device Dissipation	P _D	230	W
Junction Temperature	T _J	200	°C
Storage Temperature Range	T _{STG}	-65 to +150	°C

ELECTRICAL CHARACTERISTICS

CHARACTERISTICS	SYMBOL	TEST CONDITIONS	MIN.	TYP.	MAX.	UNITS
Drain-Source Breakdown Voltage	V _{(BR)DSS}	I _D =100mA, V _{GS} =0	65	-	-	V
Zero Gate Voltage Drain Current	I _{DSS}	V _{GS} =0V, V _{DS} =28V	-	-	5	mAdc
Gate-Source Leakage Current	I _{GSS}	V _{GS} =20V, V _{DS} =0V	-	-	1	uAdc
Gate Threshold Voltage	V _{GS(th)}	V _{DS} = 10 V, I _D = 200mA	2.0	-	4.5	V
Forward Transconductance	g _{fs}	V _{DS} = 10 V, I _D = 8A	5	7.5	-	mhos
Input Capacitance	C _{iss}	V _{DS} = 28 V, V _{GS} = 0 V, f = 1.0 MHz	-	460	-	pF
Output Capacitance	C _{oss}		-	320	-	pF
Reverse Transfer Capacitance	C _{rss}		-	30	-	pF
Common Source Power Gain	G _{PS}	V _{DD} =28V, P _{OUT} =150W, f=30; 30.001MHz, I _{DQ} = 250 mA	17.0	-	-	dB
Drain Efficiency	η _D		35	-	-	%
Common Source Power Gain	G _{PS}	V _{DD} =28V, P _{OUT} =150W, f=108MHz, I _{DQ} = 250mA	-	14.0	-	dB
Drain Efficiency	η _D		-	70.0	-	%
Intermodulation Distortion	IMD	V _{DD} = 28 V, P _{out} = 150 W (PEP), f ₁ = 30 MHz, f ₂ = 30.001 MHz, I _{DQ} = 1 A	-	-	-30	dB

Note : Above parameters , ratings , limits and conditions are subject to change.