

DESCRIPTION

Silicon N-channel enhancement mode vertical D-MOS transistor is designed for broadband HF and VHF. The part makes possible solid state transmitters for FM broadcast or TV channel frequency bands.

FEATURES

- Output Power: 80 W
- Power Gain: 13 dB Typ@150M, 28V
- Efficiency: 55% Min

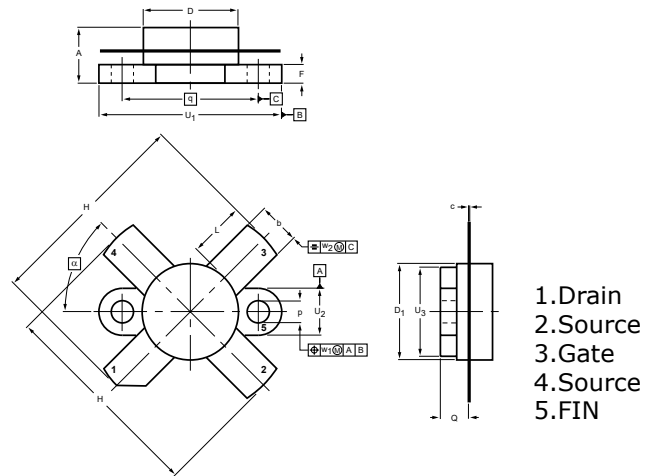

DIMENSIONS

NOTE: ALL ELECTRODES ARE ISOLATED FROM FLANGE.

UNIT	A	b	c	D	D ₁	F	H	L	p	Q	q	U ₁	U ₂	U ₃	w ₁	w ₂	α
mm	7.27	5.82	0.16	12.86	12.83	2.67	28.45	7.93	3.30	4.45	18.42	24.90	6.48	12.32	0.51	1.02	45°
	6.17	5.56	0.10	12.59	12.57	2.41	25.52	6.32	3.05	3.91		24.63	6.22	12.06			
inches	0.286	0.229	0.006	0.506	0.505	0.105	1.120	0.312	0.130	0.175	0.725	0.98	0.255	0.485	0.02	0.04	
	0.243	0.219	0.004	0.496	0.495	0.095	1.005	0.249	0.120	0.154		0.97	0.245	0.475			

MAXIMUM RATINGS

CHARACTERISTICS	SYMBOL	RATINGS	UNITS
Drain-Source Voltage	V _{DSS}	65	V
Drain-Gate Voltage	V _{DGR}	65	V
Gate-Source Voltage	V _{GS}	±40	V
Drain Current – Continuous	I _D	9	A
Total Device Dissipation	P _D	220	W
Junction Temperature	T _J	200	°C
Storage Temperature Range	T _{STG}	-65 to 150	°C

ELECTRICAL CHARACTERISTICS

CHARACTERISTICS	SYMBOL	TEST CONDITIONS	MIN.	TYP.	MAX	UNITS
Drain-Source Breakdown Voltage	V _{(BR)DSS}	I _D =50mA, V _{GS} =0	65	-	-	V
Zero Gate Voltage Drain Current	I _{DSS}	V _{GS} =0V, V _{DS} =28V	-	-	2	mA
Gate-Source Leakage Current	I _{GSS}	V _{GS} =40V, V _{DS} =0V	-	-	1	uA
Gate Threshold Voltage	V _{GS(th)}	V _{DS} = 10 V, I _D = 50mA	1.0	3.0	6.0	V
Forward Transconductance	g _{fs}	V _{DS} = 10 V, I _D = 2A	1.8	2.2	-	mhos
Input Capacitance	C _{iss}	V _{DS} = 28V, V _{GS} = 0V, f = 1.0 MHz	-	140	-	pF
Output Capacitance	C _{oss}		-	105	-	pF
Reverse Transfer Capacitance	C _{rss}		-	10	-	pF
Common Source Power Gain	G _{PS}	V _{DD} =28V, P _{OUT} =80W,	11.0	13.0	-	dB
Collector Efficiency	η _C	f=150MHz, I _{DQ} =50mA	55.0	60.0	-	%

Note : Above parameters , ratings , limits and conditions are subject to change.